



OCTANE-IM
PORTABLE OCTANE METER

Operating manual

TABLE OF CONTENTS

INTRODUCTION.....	3
Intended Use.....	3
Appearance and Part Names.....	3
List of Abbreviations.....	4
Indicator and Keypad Description.....	4
Other Parts and Accessories	4
Power	5
Charging and Replacing of the Battery	5
USING THE OCTANE-IM	6
Preparation.....	6
Powering Octane Meter On and Off.....	6
Powering Backlight On and Off	6
Display in the Basic Mode.....	7
Main Menu of Octane Meter.....	8
Measurement Mode Selection	9
Current Calibration Selection.....	9
Zero Adjustment.....	9
Taking Measurements	10
Managing Calibrations	10
Working with Logbook.....	13
Octane Meter Customization	14
PC SOFTWARE	16
Software Purpose.....	16
Software Installation	16
Software Utilization	16
DIFFERENT APPROACHES OF CREATING AND APPLYING USER'S CALIBRATIONS	17
GENERAL SPECIFICATIONS	18

This manual provides the information needed to operate the OCTANE-IM portable octane meter.

! *WARNING: The OCTANE-IM portable octane meters are NOT explosion-proof: reasonable care MUST be used in handling these instruments.*

INTRODUCTION

Intended Use

The OCTANE-IM portable octane meter is meant for defining:

- octane numbers of motor fuel, complying with octane numbers, calculated by research method (ASTM D2699) and motor method (ASTM D2700);
- cetane numbers of diesel fuel, complying with cetane numbers, calculated according to ASTM D613.

The OCTANE-IM is intended to be used:

- in refineries to control quality of fuel components and their blends;
- for fuel checking during transportation, storage and consumption.

Appearance and Part Names

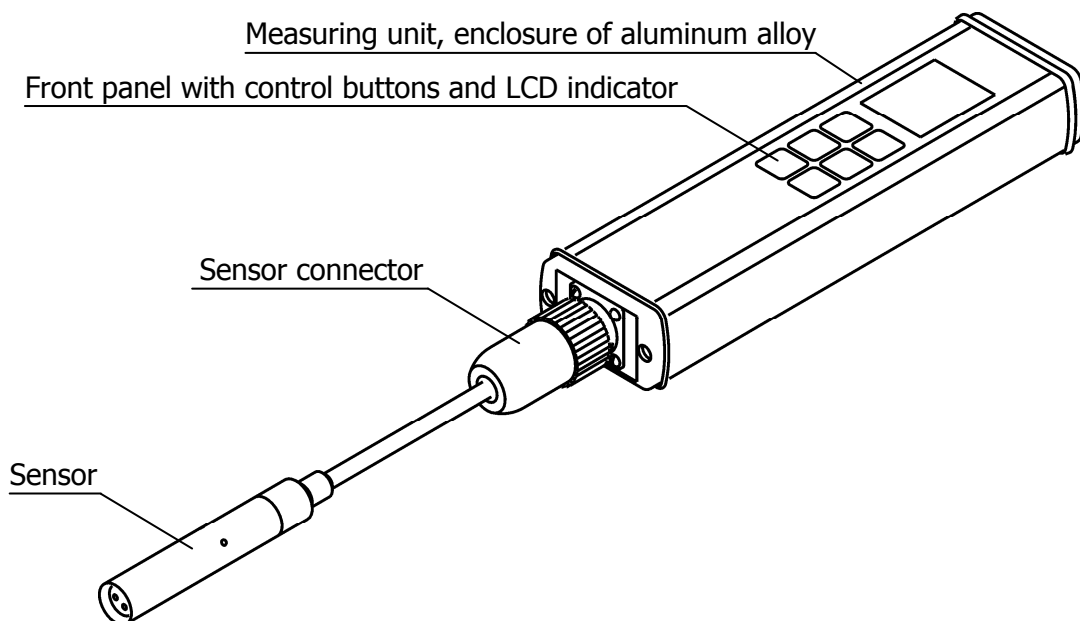

! *NOTE: The sensors of different instruments are not reciprocal.*

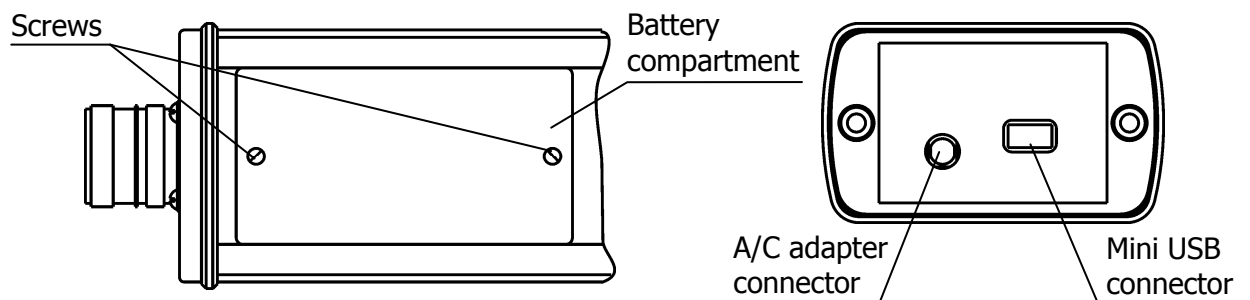

List of Abbreviations

DOI — dielectric octane index.

DCI — dielectric cetane index.

RON — octane number according to research method.

MON — octane number according to motor method.

CN — cetane number.

Indicator and Keypad Description

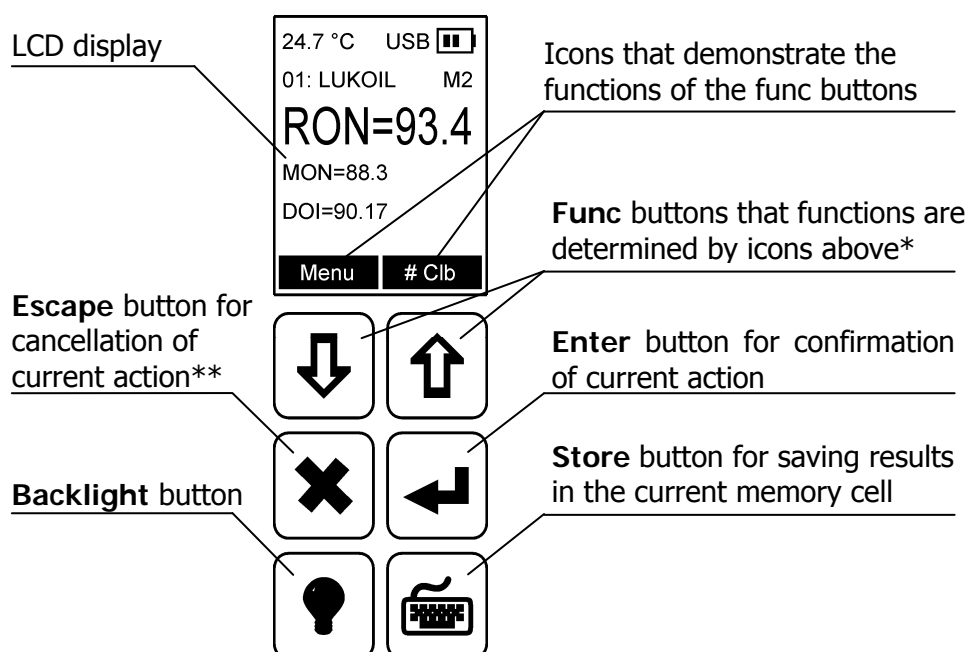

* — when lack of icons, the buttons are used for moving the cursor or changing parameter values;

** — pressing and holding it for more than 3 seconds will turn the power on/off.

Other Parts and Accessories

The OCTANE-IM package includes the following parts and accessories:

- Measuring unit
- Detachable sensor
- USB cable , 1.8 meters long
- OMEN software CD
- A/C adapter
- Two AA-size rechargeable batteries
- Carrying case
- Operating manual
- Calibration manual

Contact TERMEX if you would like to purchase additional accessories.

Power



The OCTANE-IM can be powered by batteries, by USB or an A/C Adapter.

When connecting to the A/C adapter or computer, OCTANE-IM will automatically turn itself on even if there is not enough battery to operate the unit. In this case the symbol "___" will appear on the display.

If OCTANE-IM is in charging mode or connected to a computer it cannot be turned off.

Charging and Replacing of the Battery

The level of the battery is indicated. All of its possible states are shown in the table below.



	The battery is full. Charging is not necessary.
	The battery is partially charged. Charging is not necessary.
	The battery is low. Charge the battery.

The battery must be charged at temperature within +10 to +30 °C. If OCTANE-IM had been operated in the environment colder than 5 °C, it is necessary to let the unit sit in room temperature for 4 hours.

To charge the battery:

- connect the A/C adapter cable to the A/C adapter jack located on the top side of the measuring unit;
- plug the A/C adapter to the power outlet.

! *WARNING: Don't use A/C adapters from other devices.*

The charging process is indicated by alternate symbols  and  on the display. When the charge is complete the indication  will appear.

To stop the charging process:

- unplug the A/C adapter from the power outlet;
- disconnect the A/C adapter cable from the A/C adapter jack on the top of the measuring unit.

Charging a completely discharged battery may take up to 8 hours or even more.

! *NOTE: While charging all the audible signals are missing.*

To replace the battery:

- turn OCTANE-IM off;
- undo the screws and take off the lid of the battery compartment, located on the back of the measuring unit;
- remove old batteries;
- put new batteries in; be sure that the batteries are oriented as indicated in the battery compartment;
- put the lid and screws back.

! *NOTE: Use ONLY NiMH batteries with initial capacity of 2100 to 2700 mAh.*

USING THE OCTANE-IM

! *NOTE: Throughout this manual, keystrokes are represented in **bold type**; references to messages on the OCTANE-IM display are in "quotes."*

Before using OCTANE-IM octane meter, carefully read the operating manual.

Preparation

Move sensor connector into its mating part on the unit case while aligning the clamps. Fix the sensor by screwing coupling nut.

Charge the battery if it is necessary.

! *WARNING: While using the unit in cold temperature make sure to wear gloves in order not to get frostbite.*

Powering Octane Meter On and Off



To turn OCTANE-IM on, press and hold **Escape** button for more than 3 seconds. The instrument will turn on if the battery is charged enough.

To turn OCTANE-IM off, press and hold **Escape** button for more than 3 seconds again.

! *NOTE: The OCTANE-IM will automatically turn itself off in case of the battery being too low to operate. This precaution was made in order to make the life of the unit last longer and to prevent the battery total discharge.*

Powering Backlight On and Off



To turn the backlight on, push **Backlight** button.

To turn the backlight off, push **Backlight** button again.

Display in the Basic Mode

Octane meter can work in two modes:

- octane number measuring;
- cetane number measuring.

The data on the display for octane number measuring mode is shown below:

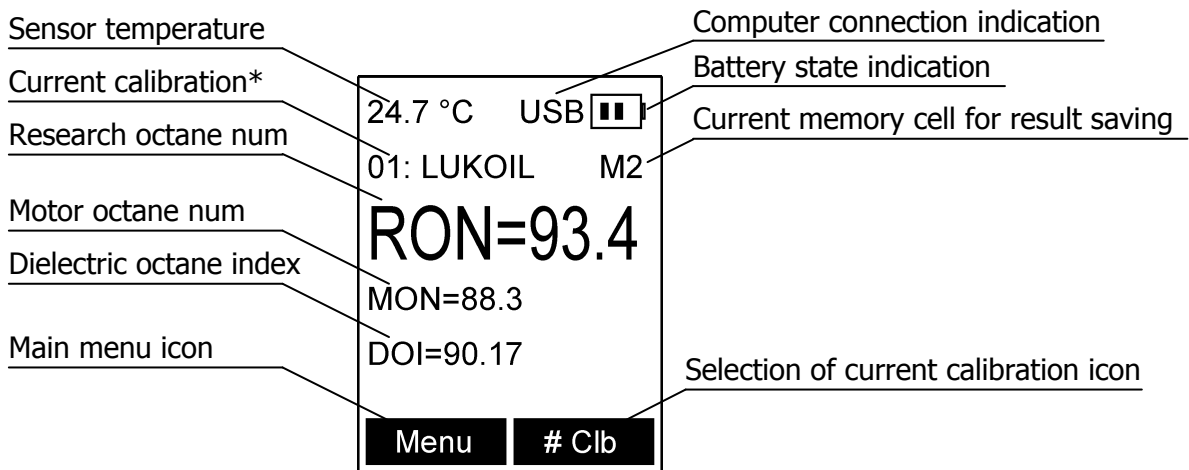

* — consists of index and title, title may be missing.

! **NOTE:** In case of sensor not being connected to the unit or being out of order, MON and DOI will not be indicated on the display and research octane number appears as "RON=".

The data on the display for cetane number measuring mode is shown below:

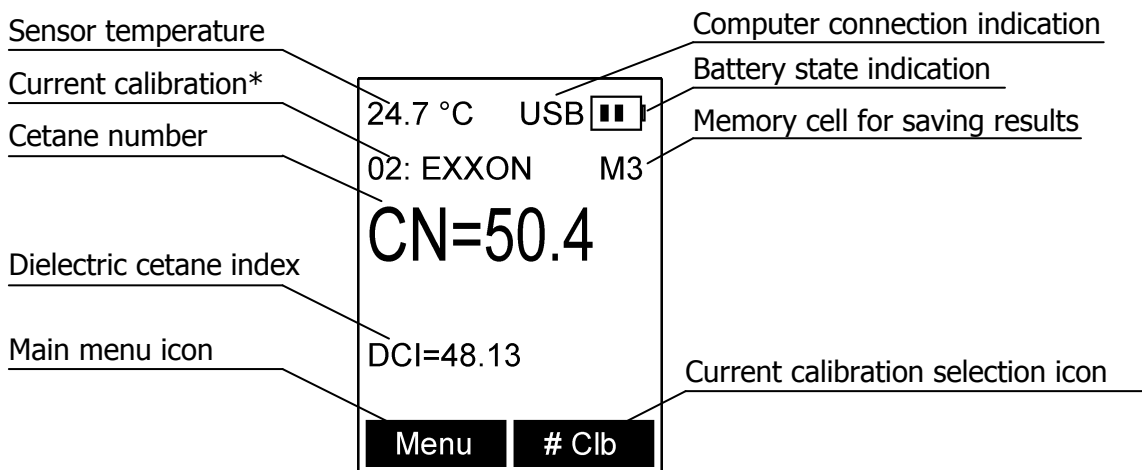

* — consists of index and title, title may be missing.

! **NOTE:** In case of sensor not being connected to the unit or being out of order, DCI will not be indicated on the display and cetane number appears as "CN=".



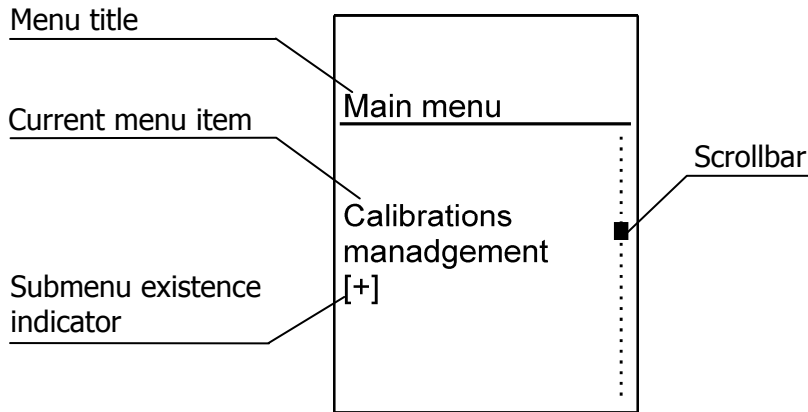

Main Menu of Octane Meter

Mode operating and calibration of octane meter is realized through the main menu. Main menu is a set of items, which can be a command or submenu. To navigate the main menu and carry out different instructions, the \uparrow , \downarrow , \leftarrow , \times buttons are used. To select the main menu, use \downarrow button when appropriate icon for this func button is on the display. Pressing any active button is always accompanied by a short audible signal.

The display view while navigating through the main menu is shown below:



The table below contains the information of the buttons and their intended use:

<div style="border: 1px solid black; padding: 2px; display: inline-block;">Menu</div> 	Select the main menu
 	Moving between menu items
	Instruction execution or open submenu
	Cancel the instruction execution or return to the upper level of the menu

Main menu tree is shown below. A menu item with a [+] symbol means that it contains a submenu.

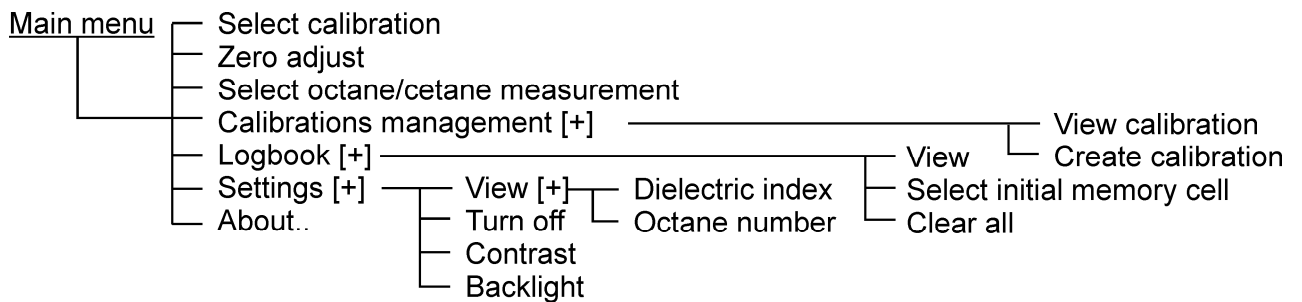

Measurement Mode Selection

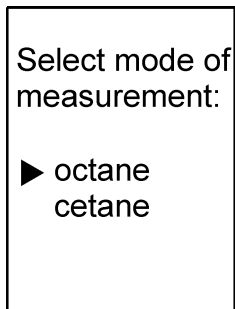

The OCTANE-IM is meant to measure both octane number of gasoline and cetane number of diesel fuel. To select the type of measurement:

- select "Main menu" -> "Select measurement mode";
- select the measurement mode you need with \uparrow , \downarrow buttons;
- press \leftarrow for confirmation, \times — to cancel.

Current Calibration Selection

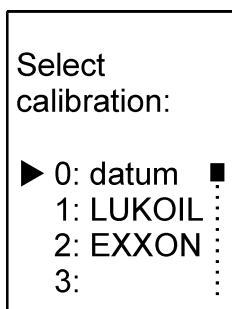

The OCTANE-IM is able to determine octane/cetane number according to the factory or one of the user's calibrations. To select the current calibration:

- select "Main menu" -> "Select calibration";
- select the calibration you need with \uparrow , \downarrow buttons;
- press \leftarrow for confirmation, \times — to cancel.

Title and number of the current calibration will be indicated on the display.

Clb



A shortcut to selecting the current calibration can be executed by pressing the \uparrow button when the correlating icon is indicated on the display. Pressing this button one time will open the calibration selector.

Zero Adjustment

Zero adjustment is meant to compensate for long-term sensor drift. Zero adjustment is performed by means of n-heptane which must be especially pure. Repeat zero adjustment procedure at least once a week.

To adjust zero:

- Select "Main menu" -> "Zero adjust".
- Immerse sensor into n-heptane and make a few movements in vertical direction to make sure that the sensor is completely submerged.

The display will indicate the information shown below:

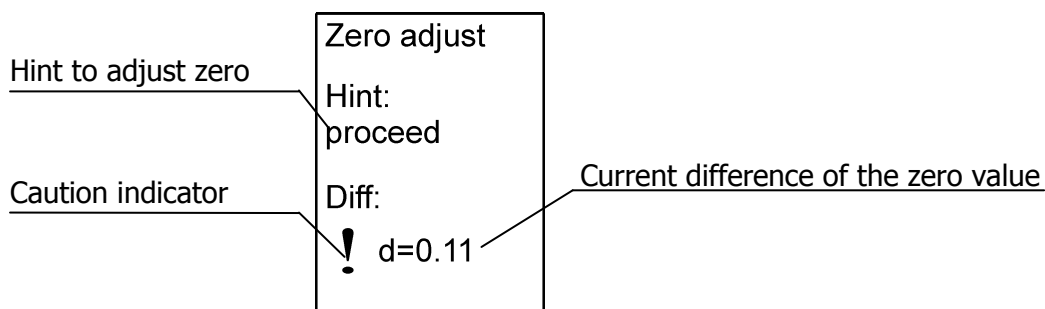

In the bottom of the display you will see the difference between the zero value of the instrument and the current measured value of zero. Depending on the difference, in the middle of the display you will see a recommendation: "proceed" — meaning the difference is significant, and

you need to make zero adjustment; "refuse" — the difference is insignificant, no need in zero adjustment; "error" — the sensor is out of order or is not connected to the unit.

When the difference is exceptionally significant, an exclamation mark will appear in the left part of the display. This alerts the user to be extremely careful with the procedure of zero adjustment. Also the presence of this symbol should remind you to make sure that n-heptane is of required level of fineness.

- ! *NOTE: The presence of the caution symbol has no affect on the procedure of zero adjustment.*
- To complete the operation hold \leftarrow button for 1 second or press \times button to cancel the operation.

When operation is finished, "Zero adjustment done" message appears.

- ! *NOTE: If zero adjustment proceeds after "error" indication, "Zero adjustment error" message appears, and the operation will be cancelled.*
- Press \times button 3 times to return to the basic mode.

Taking Measurements

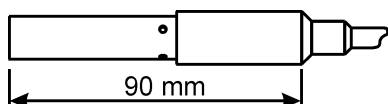

- ! *NOTE: While taking measurements please keep the minimal dipping of the sensor.*

Before taking measurements:

- select measurement mode;
- adjust zero;
- select current calibration.

To take measurements:

- place sensor in the fuel, make sure that the sensor is completely submerged;
- take readings of octane/cetane number;
- if needed, save the result in logbook by pressing  button;
- remove the sensor and wipe with a tissue;
- if needed, repeat the procedure for other fuels.

- ! *NOTE: Sometimes results may look like "RON=---" or "CN=---". That means that either the current calibration is empty or contains errors. To eliminate the errors see "Managing calibrations". In either case it is not a malfunction.*

Managing Calibrations

Calibration defines dependence of octane number (RON, MON) from dielectric octane index (DOI). Likewise for diesel fuel, calibration defines dependence of cetane number (CN) from dielectric cetane index (DCI).

Dielectric octane/cetane index is a value of dielectric permeability of the fuel brought to the range of:

- 84.25-104.00 for octane number measuring;
- 45.61-56.30 for cetane number measuring.

The dielectric octane/cetane index does not depend on the specific octane meter and serves as a measure when comparing the readings of different octane meters.

Example of the mentioned dependence is shown below. Octane meter, having measured DOI/DCI, calculates RON, MON (CN) using the stated dependence. This dependence is saved as one of the calibrations.

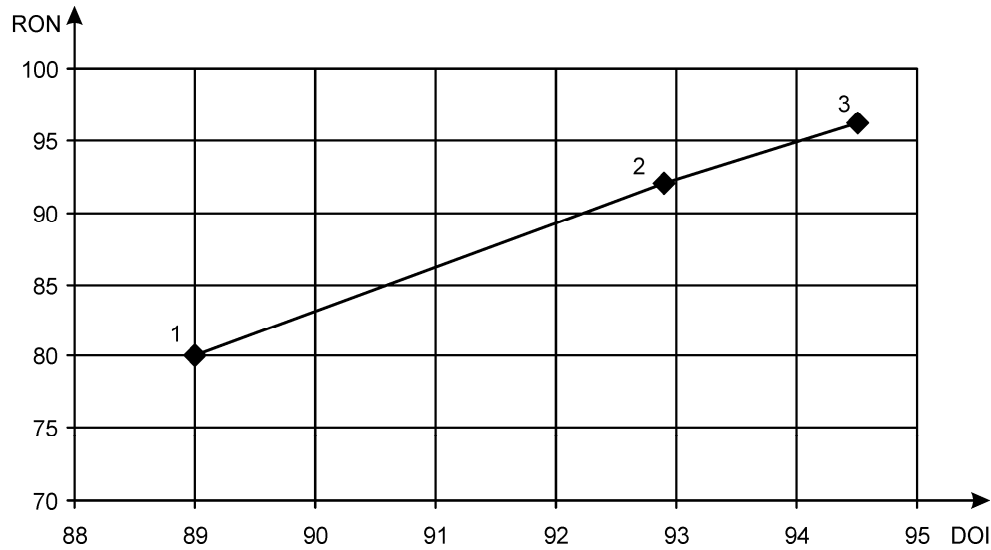

Octane meter can save up to 11 calibrations for each measurement mode, listed from 0 to 10. The calibration 0 is a factory calibration and cannot be modified by user. Calibrations from 1 to 10 are meant for customer's use and can be adjusted according to their needs.

Definition of the calibration is carried out according to the piecewise linear approximation of a set of experimental points. The ultimate amount of points should be from 1 to 4. The calibration points in figure above are marked with 1, 2 and 3.

To create calibration, it is necessary to have 1 to 4 fuel standards with known values of octane/cetane numbers.

The process of creating calibration is as follows:

- Step 1 – measuring by octane meter the values of DOI/DCI for each fuel standard;
- Step 2 – compiling of calibration table (see below);
- Step 3 – saving this table in the memory of the octane meter.

Creating calibration. Step 1:

- make the value of DOI/DCI be shown on the display;
- take readings of DOI/DCI of every fuel standard.

! *The value of octane/cetane number might look like "RON=----" ("CN=----") which is not considered to be an error.*

Creating calibration. Step 2:

- based on the measured values of DOI/DCI and known values of RON, MON (CN) of fuel standards, complete the following table:

For octane number measuring mode					For cetane number measuring mode				
	1	2	3	4		1	2	3	4
DOI					DCI				
RON					CN				
MON									

If there are less than 4 fuel standards, leave the remaining columns empty.

Creating calibration. Step 3:

- select the needed calibration as the current one;
- select "Main menu"->"Calibrations management"->"Create calibration";

The information shown below will be indicated on the display. The actual view depends on the values of the current calibration.

For octane number measuring mode:

For cetane number measuring mode:

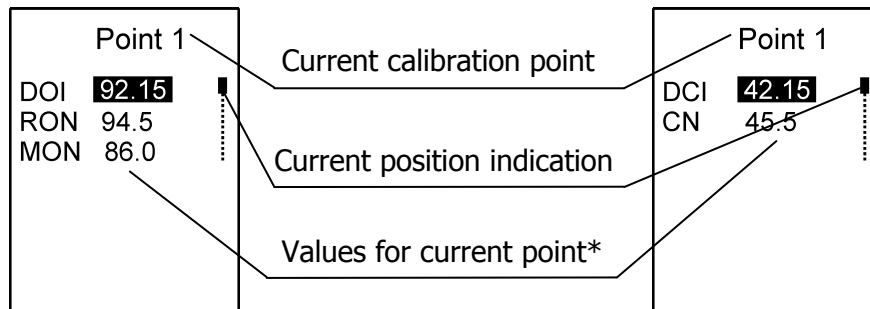

* — cursor highlights the current value that is being edited.

↑, ↓ buttons move the cursor inside the table. When the cursor reaches the lowest or highest position it goes over to the next or previous calibration point.

To enter a numerical value in the table:

- place the cursor on desired value of a desired point by means of ↑, ↓ buttons;
- press ← button to enter into number editing mode;
- enter the desired value with ↑, ↓ buttons. Hold the button to change number faster;
- press ← button to accept a new value or ✕ — to return a previous value.

Transfer the information from the calibration table to the octane meter as described above.

- for the unused points enter zero value of DOI (DCI);
- check all the entered values, correct if necessary;
- press  button, the calibration will be created with the entered values. Message "Calibration created" will appear for a short time;
- to cancel the calibration creating press ✕ button.

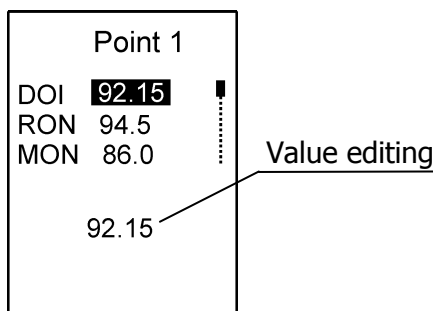

The order of entering values does not matter. Octane meter will automatically put them in the increasing order according to the values of DOI or DCI.

! *NOTE: Creation a new calibration will replace a current one.*

! *NOTE: A point that contains at least one zero value will not be included in the calibration.*

! *WARNING: Octane meter cannot verify if the entered values are right. So the values may be entered incorrectly. In this case, while measuring octane or cetane number, display will indicate the value as "RON=---" or "CN=---" while DOI or DCI values will be indicated right. In this case the calibration has to be recreated without entering wrong data. For example, a calibration that includes two or more points with the same values of DOI (DCI) is considered as wrong.*

When creating a calibration, a message "Calibration contains errors" may be shown on the display. This happens when a user creates a calibration operating with only one point and its value of DOI or DCI equals 104.0 ± 1.0 or 56.3 ± 1.0 respectively. To eliminate the error do one of the following:

- change the value of the wrong DOI or DCI point to the value out of the 104.0 ± 1.0 or 56.3 ± 1.0 range respectively;
- or add at least one more point to the calibration.

To proceed after the error message, press ✕ button. The error message will also appear every time when selecting new current calibration if chosen one contains the mentioned error.

To look through contents of any calibration:

- select the desired calibration as current one;
- select "Main menu"->"Calibrations management"->"View calibration" and press \leftarrow button;
- calibration information will be shown on the display;
- select the desired point with \uparrow , \downarrow buttons;
- press \times button to exit.

Working with Logbook

Octane meter can save up to 10 measurement results in the logbook, which consists of ten memory cells. A measurement result is a set of the following values: calibration index and calibration title (if any); DOI, RON, MON — for octane number measuring mode; DCI, CN — for cetane number measuring mode. A memory cell that will save the next measurement result is indicated on the display. Memory cell numeration starts with zero.

To save a result in the current memory cell of the logbook press  button.

After saving each result, memory cell index automatically increases by 1. When reaching the M9 value, index goes back to M0. That means that the memory cells are circled.

To view the previously saved measurement results:

- select "Main menu"->"Logbook"->"View" and press \leftarrow button;
- select the desired memory cell with \uparrow , \downarrow buttons;
- press \times button to exit.

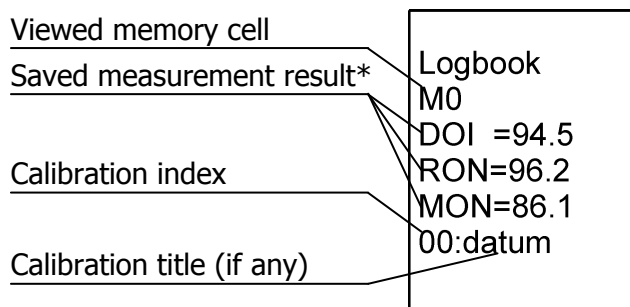

* — DCI and CN will be shown in cetane number measuring mode.

To select initial memory cell which starts the result saving process:

- select "Main menu"->"Logbook"->"Select initial memory cell" and press \leftarrow button;
- select the desired initial memory cell with \uparrow , \downarrow buttons;
- press \leftarrow button to confirm selection or \times — to cancel.

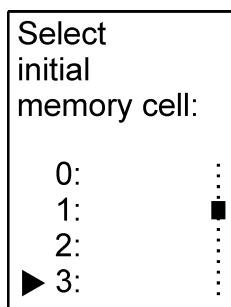

To erase all the previously saved results select "Main menu"->"Logbook"->"Clear all" and press \leftarrow button. A message "All log's data deleted" will appear for a short time. The logbook will be erased and initial memory cell will be located in M0.

Octane Meter Customization

A user can adjust some of the octane meter operation factors according to their needs. Those factors are:

- time of automatic backlight shut off;
- time of automatic instrument shut off;
- display contrast;
- DOI/DCI indication,
- form of octane number.

To increase the time of continuous running, set the time of automatic backlight shut off:

- select "Main menu"->"Settings"->"Backlight" and press \leftarrow button;
- select desired time of backlight shutting off with \uparrow , \downarrow buttons;
- press \leftarrow button to confirm selection or \times — to cancel.

Shut off
backlight
after:

▶ manually
15 seconds
30 seconds
60 seconds

Display backlight will automatically shut off in chosen time if no buttons are pressed.

When function "manually" is chosen, backlight power-
ing on/off is controlled by a user with the  button.

To increase the time of continuous running, set the time of automatic instrument shut off:

- select "Main menu"->"Settings"->"Shut off" and press \leftarrow button;
- select desired time of instrument shutting off with \uparrow , \downarrow buttons;
- press \leftarrow button to confirm selection or \times — to cancel.

Shut off
instrument
after:

▶ never
1 minute
10 minutes
30 minutes

The instrument will automatically shut off in chosen time if no buttons are pressed.

When function "never" is chosen, to shut off the in-
strument press and hold \times button.

To set display contrast:



$\odot \pm 80$

- select "Main menu"->"Settings"->"Contrast" and press \leftarrow button;
- select desired contrast level with \uparrow , \downarrow buttons;
- press \leftarrow button to confirm selection or \times — to cancel.

Contrast setting might be needed in case of ambient temperature change.

If the display is blank with the current contrast set, follow these instructions:

- to make sure that the unit is on, turn the backlight on/off with  button. Turn octane meter on if it is off;

- press **X** button 5 times;
- press **↓** button 6 times;
- press **←** button;
- press **↓** button twice;
- press **←** button;
- make the image visible with **↑**, **↓** buttons;
- press **←** button.

Display indicates DOI or DCI by default. To customize its indication:

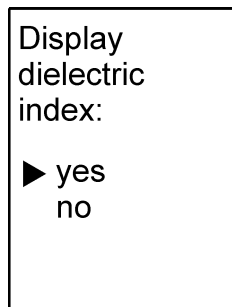

- select "Main menu"->"Settings"->"View"->"Dielectric index" and press **←** button;
- select desired DOI/DCI indication with **↑**, **↓** buttons;
- press **←** button to confirm selection or **X** — to cancel.

In octane number measuring mode one of the numbers (RON, MON) is bold. To select which number should be bold:

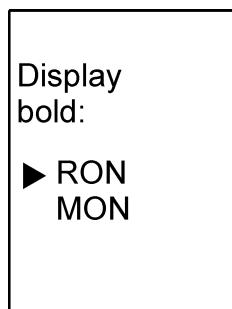

- select "Main menu"->"Settings"->"View"->"Octane number" and press **←** button;
- select desired octane number indication with **↑**, **↓** buttons;
- press **←** button to confirm selection or **X** — to cancel.

PC SOFTWARE

Software Purpose

PC software is intended for creating a connection between octane meter and computer by means of USB interface, to retrieve previously saved results and managing user's calibrations.

Software Installation

Our package contains a CD with the needed software. To install software on PC:

- insert CD into CD-ROM;
- start setup.exe;
- complete installation, following instructions.

After installing software, «Omen» icon will appear on desktop and in the Start menu.

Software Utilization

To exchange data between computer and octane meter:

- plug the USB cable into instrument's connector;
- connect the USB cable to PC. If octane meter is off it will automatically turn on. An appropriate symbol will appear on the display;
- when connecting octane meter to PC for the first time a message "New device found" will appear. After that all required drivers will be automatically installed;
- run «Omen» software.

If you have any problems while using the program, press F1 for help. It contains all the necessary information for successful operating.

DIFFERENT APPROACHES OF CREATING AND APPLYING USER'S CALIBRATIONS

Depending on the use of octane meter, there are different approaches of creating and applying user's calibrations. This chapter provides two of the most common approaches. Their operation applies to both octane number measuring mode and cetane number measuring mode. The approaches are based on measuring fuel octane number.

Approach 1. Allows to determine octane number of a fuel if its manufacturer is known. This approach is realized by creation of a few calibrations. The number of calibrations is determined by the number of gasoline manufacturers in the particular region. Each calibration is based on 1-4 different types of gasoline from one manufacturer.

For example, let the following manufacturers functioning in the particular region be (names are imaginary): Rocket Fuel, Petrol Plus, Super Fuel and Gasoline Extra. For each manufacturer we chose the following types of gasoline:

- Regular, Premium, Super — for Rocket Fuel.
- Normal, Regular, Super — for Petrol Plus.
- Normal, Premium — for Super Fuel.
- Normal, Regular, Premium, Super — for Gasoline Extra.

For each manufacturer create a separate calibration according to their gasoline types. Calibration 1 should be created for Rocket Fuel and its gasoline types Regular, Premium, Super; calibration 2 for Petrol Plus — Normal, Regular, Super etc. To create calibrations "OMEN" software can be used. In that case name calibrations according to the manufacturers 1:"Rocket Fuel", 2:"Petrol Plus", 3:"Super Fuel", 4:"Gasoline Extra". To take measurements according to approach 1:

- select the appropriate calibration for desired manufacturer as current one;
- take measurements.

! *NOTE: Factory calibration #0 uses approach 1.*

Approach 2. Allows to determine octane number of a fuel if its manufacturer is unknown. This approach is realized by creation of a few calibrations. Number of calibrations depends on number of tested types of gasoline. Each calibration is based on of 1 to 4 different types of gasoline but from different manufacturers.

For example, as stated above, let the following manufacturers functioning in the particular region be (names are imaginary): Rocket Fuel, Petrol Plus, Super Fuel and Gasoline Extra. We chose the following gasoline types from each manufacturer: Normal, Regular, Premium. Based on 4 gasoline samples of Normal type we created calibration 5. Likewise, based on the gasoline samples of Regular we created calibration 6 and calibration 7 for gasoline samples of Premium. For creating calibrations, "OMEN" software can be used. In that case name calibrations according to their type: 5: Normal, 6: Regular, 7: Premium. To take measurements according to approach 2:

- select the appropriate calibration for desired gasoline type as current one;
- take measurements.

If the gasoline type is unknown, to determine it, approach 1 can be performed.

Both approaches can coexist in the instrument at the same time.

GENERAL SPECIFICATIONS

Measuring range:

Octane number (RON, MON)

47...120 units

Cetane number (CN)

30...60 units

Uncertainty of measurement:

Octane number (RON, MON)

±1.0 units

Cetane number (CN)

±1.0 units

Display resolution:

0.1 unit

Minimum volume of sample:

50 cm³

Minimum depth of sensor immersion:

90 mm

Measurement time:

if sample temperature differs from sensor's by no more than 10 °C

30 sec

if sample temperature differs from sensor's by no more than 50 °C

180 sec

Dimensions:

470×60×35 mm

Weight:

0.7 kg

Power supply: 2 NiMH AA-size rechargeable batteries

Warranty:

2 years