



LTI
LABORATORY ELECTRONIC
THERMOMETERS

Operating manual

TABLE OF CONTENTS

INTRODUCTION	3
Intended Use	3
Appearance and Part Names.....	4
Indicator Description.....	4
Other Parts and Accessories	5
Replacing of the Battery.....	6
Principle of Operation.....	7
USING The LTI.....	8
Preparation	8
Operating Limitations.....	8
Taking Measurements.....	9
Optional PC SOFTWARE	10
Software Purpose	10
Software Installation.....	10
Software Utilization.....	10
GENERAL SPECIFICATIONS.....	11

This manual provides the information needed to operate the LTI laboratory electronic thermometers.

INTRODUCTION

Intended Use

The LTI thermometers are meant for measuring temperatures of various objects in laboratories in manufacturing enterprises and research institutions.

There are 3 models of the LTI thermometers, differ in measuring range:

Model	Measuring range
LTI-N	-50...+300 °C
LTI-M	-196...+150 °C
LTI-P	0...+500 °C

! *WARNING: The LTI laboratory electronic thermometers are NOT explosion proof: reasonable care MUST be used in handling these instruments.*

Appearance and Part Names

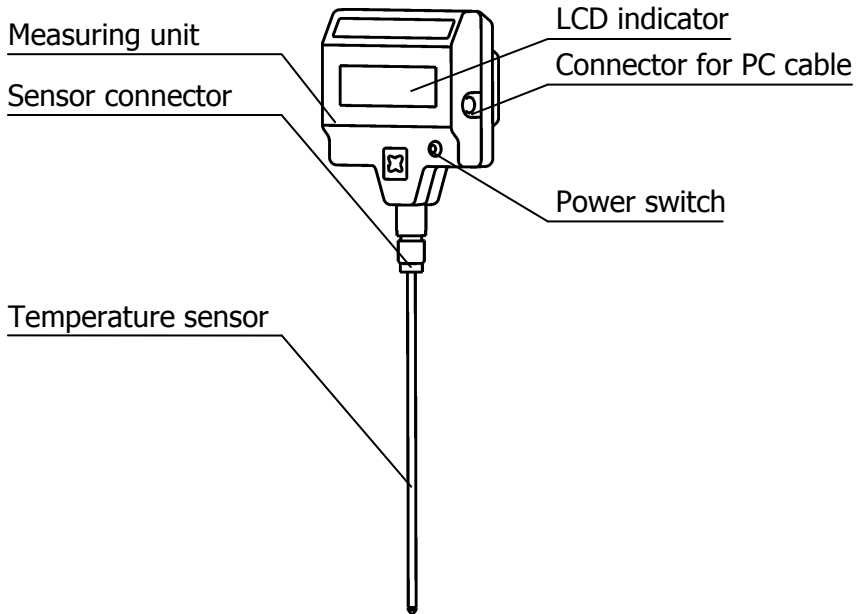

! *NOTE: The sensors of different instruments are not reciprocal.*

Indicator Description

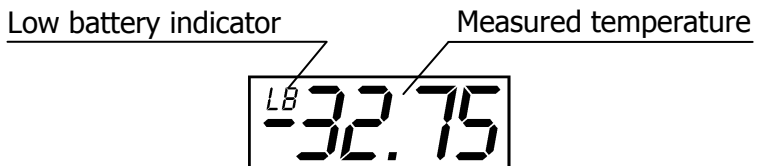

If the sensor temperature is out of the measuring range, symbol «----» will be indicated on the display.

If the sensor is not connected to the measuring unit, symbol «----» will also be indicated on the display.

Other Parts and Accessories

The LTI package includes the following parts and accessories:

- Measuring unit
- Detachable temperature sensor
- Two AAA-size alkaline batteries preset in measuring unit
- Operating manual
- Calibration certificate
- Piece of DualLock tape

Contact TERMEX if you would like to purchase additional accessories:

- Sensor extension cable
- THERMOCHART software CD
- PC data cable

Replacing of the Battery

The LTI thermometers are powered by two AAA-size alkaline batteries.

How often you need to replace the batteries depends on the battery type and the mode you use to operate thermometer. The regular alkaline batteries must last a few months of free-running instrument operation. When the instrument is connected to computer it consumes a small amount of energy, therefore reduces the life of the batteries. As soon as indication <LB> appears on the display, replace the old batteries.

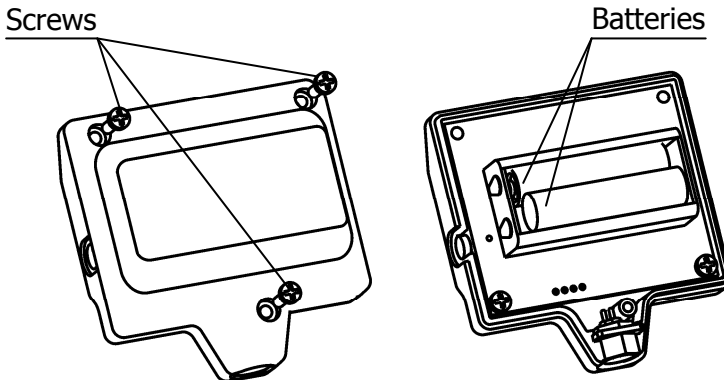

To replace the batteries:

- turn LTI off;
- undo the screws and take off the cover of the battery compartment, located on the back of the measuring unit;
- remove old batteries;
- put new batteries in; be sure that the batteries are oriented as indicated in the battery compartment;
- put the cover and screws back.

Principle of Operation

Operation principle of the LTI thermometers is based on measuring of a sensor element resistance its further conversion into temperature value according to the Calendar-Van Dusen equation:

$$R_t = R_0 \cdot [1 + A \cdot t + B \cdot t^2 + C \cdot (t - 100^\circ C) \cdot t^3]$$

where R_t и R_0 — sensor element resistance at a measured temperature and zero temperature respectively;

A , B , C — calibration factors, defined during factory calibration of the thermometer, can be modified while periodic calibration.

While measuring positive temperatures, that is when $R_t > R_0$, coefficient C is taken equal to zero and the equation is written as the following:

$$R_t = R_0 \cdot [1 + A \cdot t + B \cdot t^2]$$

Miniaturized thin-film platinum RTD, applied on a ceramic substrate, is used as a sensor element. It has an excellent precision of the temperature characteristic and long-term stability.

Measuring results are indicated on a LCD indicator. To register measuring results in real-time, the thermometer can be connected to the PC with a data cable, delivered with the thermometer. Software, also delivered with the thermometer, makes possible to register measuring results both graphically and textually. Besides, the software ensures correction of calibration factors, which can be required while periodic calibration.

USING THE LTI

Preparation

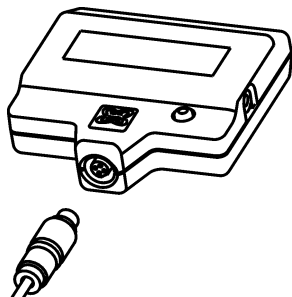

Move sensor connector into its mating part on the measuring unit while aligning the clamps. Fix the sensor by screwing coupling nut.

The temperature sensor can be connected to the measuring unit via optional extension cable. Use of extension cable does not reduce metrological performance of the LTI.

If needed, a measuring unit of the thermometer can be placed on any surface by means of duct tape DualLock which comes in our delivery package. Stick one piece of duct tape on the bump on the back of the instrument and one more on the selected surface. Before using the tape remove paper from it. The polymer lock will secure the instrument on the surface.

Turn the thermometer on by power switch button. The instrument does not require pre-warming up and is immediately ready to operate.

Operating Limitations

During thermometer operation the following limitations should be observed:

- the thermometer is not to be used for measuring temperatures out of the measuring range;
- temperature of the sensor connector or the extension cable is not to be over +70 °C;
- moisture penetration on internal electric elements of the thermometer is prohibited;
- do not use organic solvents for instrument cleaning;
- do not use the LTI for measuring substances, which can react with stainless steel — sensor rod material.

Taking Measurements

To take measurements with a declared precision the test rod of the temperature sensor should be submerged into a tested substance at a 70 mm depth. If necessary, a submersion depth of the sensor test rod could be reduced to 35 mm when an absolute error of temperature measuring is doubled.

The thermometer response time depends on a heat capacity of a tested substance and, if necessary, must be determined experimentally for each particular case.

OPTIONAL PC SOFTWARE

Software Purpose

PC software is intended for creating a connection between LTI thermometer and computer by means of RS-232 interface, to retrieve results of measurement and managing calibration factors.

Software Installation

To install software on PC:

- insert CD into CD-ROM;
- start setup.exe;
- complete installation, following instructions.

After installing software, THERMOCHART icon will appear on desktop and in the Start menu.

Software Utilization

To exchange data between computer and thermometer:

- plug the PC cable into instrument's connector;
- connect the PC cable to the computer;
- run THERMOCHART software.

If you have any problems while using the program, press F1 for help. It contains all the necessary information for successful operating.

GENERAL SPECIFICATIONS

Measuring range:

- LTI-N: -50...+300 °C
- LTI-M: -196...+150 °C
- LTI-P: 0...+500 °C

Uncertainty of measurement: $\pm(0.3 + 0.005 \times |t|)$ °C

Display resolution:

- in the range of -50 to +199.99 °C: ± 0.01 °C
- out of the range -50 to +199.99 °C: ± 0.1 °C

Minimum depth of sensor immersion: 70 mm

Dimensions:

- measuring unit: 73×77×34 mm
- sensor: $\varnothing 3.3 \times 250$

Weight: 0.2 kg

Power supply: 2 alkaline AAA-size batteries

Warranty: 2 years